

# Hypertherm®

## powermax1000® G3 SERIES™

### Hand torch parts

#### T60 consumables



Powermax1000



T60 torch

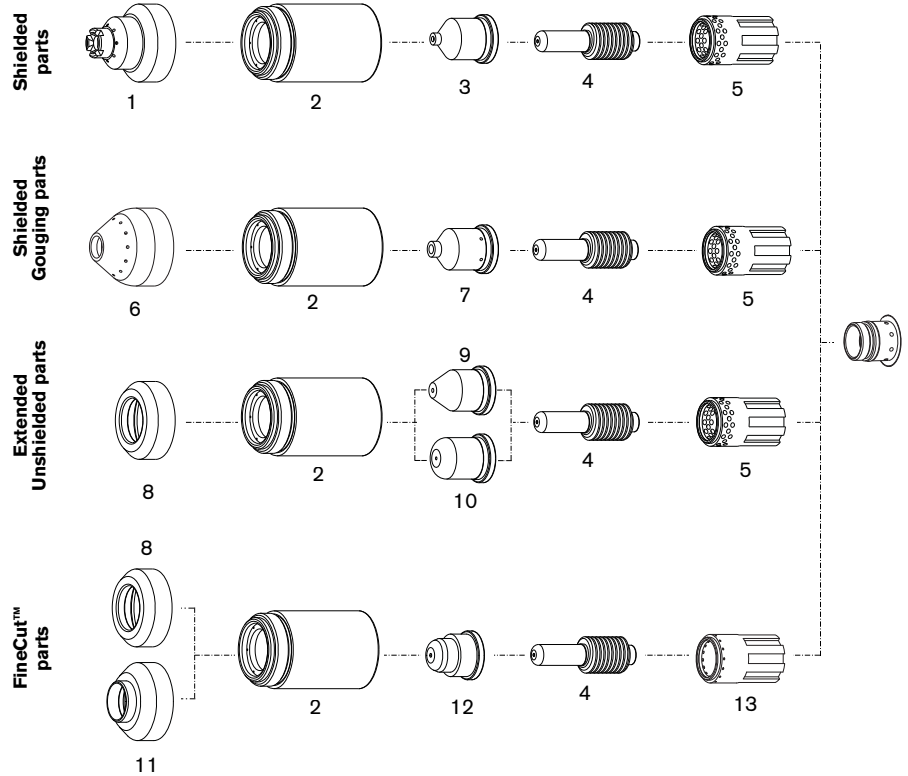

	ITEM NUMBER	PART NUMBER	DESCRIPTION	QUANTITY PER PACKAGE
Shielded parts	1	120929	Shield	1
	2	120928	Retaining cap	1
	3	120931	Nozzle, 60 amp	5
	3	120932	Nozzle, 40 amp	5
	4	120926	Electrode	5
	5	120925	Swirl ring	1
Shielded Gouging parts	6	120977	Shield, gouging	1
	2	120928	Retaining cap	1
	7	220059	Nozzle, gouging	5
	4	120926	Electrode	5
	5	120925	Swirl ring	1
Extended Unshielded parts	8	120979	Deflector	1
	2	120928	Retaining cap	1
	9	220007	Nozzle, extended, 60 amp	5
	10	220006	Nozzle, extended, 40 amp	5
	4	120926	Electrode	5
	5	120925	Swirl ring	1
FineCut™ parts	8	120979	Deflector	1
	11	220325	Deflector, CE	1
	2	120928	Retaining cap	1
	12	220329	Nozzle, T60/T80/T100	5
	4	120926	Electrode	5
	13	220327	Swirl ring	1

**Genuine Hypertherm Consumables**

*The only way to ensure maximum performance*

#### WARNING

\* In countries following CE standards, unshielded consumables may only be used in mechanized torch applications.

# Powermax1000 T60 trigger torch assembly

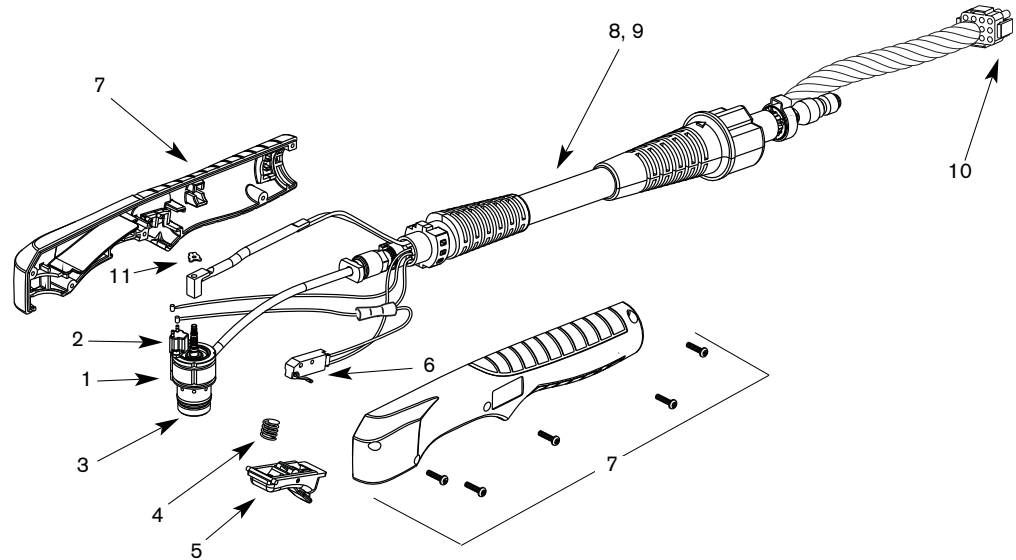

**T60 torch**

ITEM NUMBER	PART NUMBER	DESCRIPTION
	083172^	T60 hand torch assembly, 25' (7.6 m)
	083171^	T60 hand torch assembly, 50' (15.2 m)
1	128564	Kit: T60/T80 torch main body replacement
2	128639	Kit: Cap sensor switch replacement
3	128521	Kit: T60/T80, T60M/T80M torch head repair
4	027254	Trigger spring
5	002244	Safety trigger assembly
6	128642	Kit: T60/80 start switch replacement
7	128644	Kit: T60 torch handle replacement
8	128681	Kit: T60 lead replacement 25' (7.6 m)
9	128682	Kit: T60 lead replacement 50' (15.2 m)
10	128638	Kit: ETR connector repair (regional repair centers only)
	027889	Retaining clip

^ Assembly includes consumables

Hypertherm, Powermax, G3 Series, FineCut and PAC are trademarks of Hypertherm, Inc. and may be registered in the United States and/or other countries.

## Hypertherm®

www.hypertherm.com

**Hypertherm, Inc. USA** 603-643-3441 Tel 603-643-5352 Fax manual.info@hypertherm.com

**Hypertherm Automation USA** 603-298-7970 Tel 603-298-7977 Fax info@hyperthermautomation.com

**Hypertherm Plasmatechnik GmbH Deutschland** 49 6181 58 2100 Tel 49 6181 58 2134 Fax HTDeutschland.info@hypertherm.com

**Hypertherm (S) Pte Ltd. Singapore** 65 6841 2489 Tel 65 6841 2490 Fax HTSingapore.info@hypertherm.com

**Hypertherm (Shanghai) Trading Co., Ltd. PR China** 86-21 5258 3330 /1 Tel 86-21 5258 3332 Fax HTChina.info@hypertherm.com

**Hypertherm Branch of Hypertherm UK, LLC England** 00 800 3324 9737 Tel 00 800 4973 7329 Fax HTUK.info@hypertherm.com

**France (Representative office)** 00 800 3324 9737 Tél 00 800 4973 7329 Fax HTFrance.info@hypertherm.com

**Hypertherm Europe B.V. Nederland** 31 165 596907 Tel 31 165 596901 Fax HTEurope.info@hypertherm.com

**Hypertherm Japan Ltd.** 81 6 6170 2020 Tel 81 6 6170 2015 Fax HTJapan.info@hypertherm.com

**Hypertherm Brasil Ltda.** 55 11 2409 2636 Tel 55 11 2408 0462 Fax HTBrasil.info@hypertherm.com

**Hypertherm México, S.A. de C.V.** 52 55 5681 8109 Tel 52 55 5683 2127 Fax ventas@hypertherm.com.mx

**Australia/New Zealand (Representative office)** 61 (0) 7 3219 9010 Tel 61 (0) 7 3219 9012 Fax sales.au@hypertherm.com